

Towards a Local Separation Performances Estimator Using Common ICA contrast Functions ?

Frédéric Vrins, Cédric Archambeau and Michel Verleysen

Microelectronics Laboratory
Machine Learning Group
Unviersité catholique de Louvain, Belgium

www.dice.ucl.ac.be/mlg

ESANN 2004, April 29, Bruges (Belgium)

Introduction

- Source separation = optimizing a global criterion
- In real-world applications, all **sources** are **not simultaneously extracted** in the **best way**
- In many applications (non-invasive Fetal ECG extraction, denoising,...), people are interested in the **optimal extraction of one particular source**

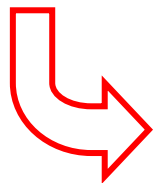

AIM: blind measurement of the extraction of one specific source ?

Outline

- Blind Source Separation
- BSS achieved by ICA
- Optimizing extraction of a specific source
- Blind criteria for local extraction ?
- Conclusion

Blind Source Separation (BSS)

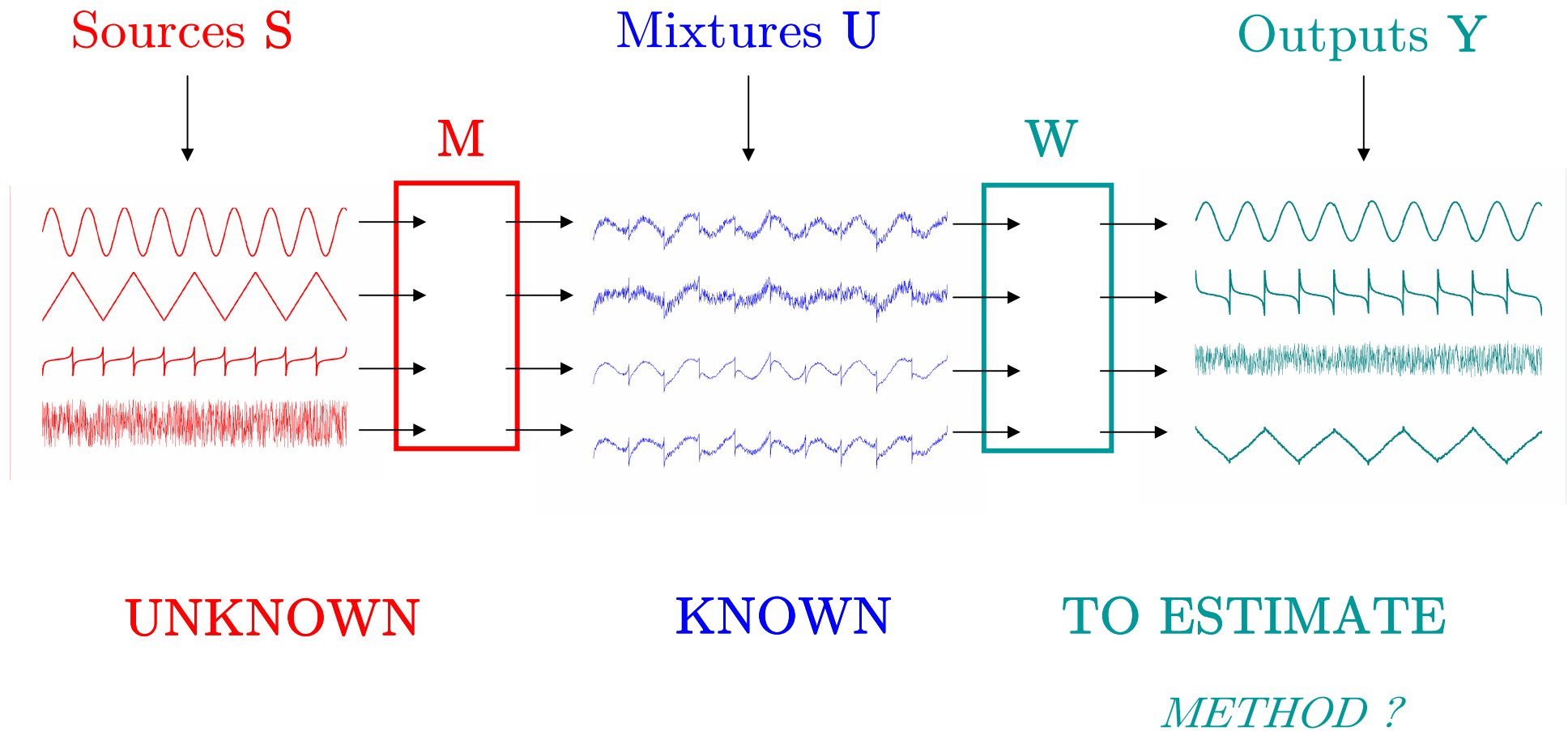

ICA can achieve BSS if ...

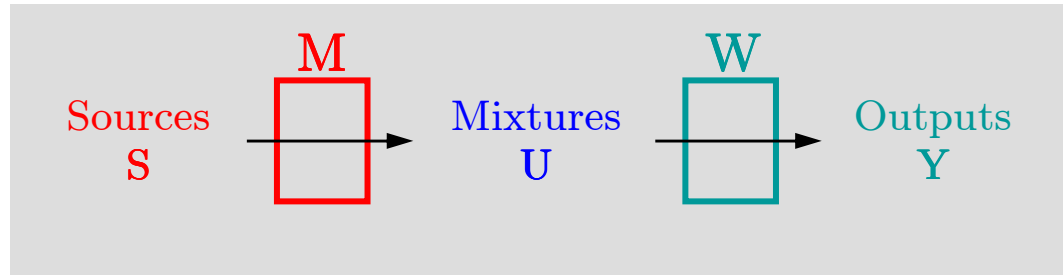

- Assumptions on S : \longrightarrow 1) independent
2) at most one is Gaussian
- Assumptions on M : \longrightarrow 1) memoryless
2) noiseless
3) linear
- THEN :

Finding W such that $Y=WM S$ are pairwise independent = ' ICA '



Y proportional to (permuted) S

Cost functions for ICA

Solving ICA = Optimizing a criterion Φ

- Independence:
 - Minimum Mutual Information
 - Cancel H.O. Cross-Cumulants
 - ...

Another point of view ?

- Nongaussianity:
 - Gaussian is maximum entropy PDF of unbounded variables
 - Mixing gaussianizes (Central Limit Theorem)

⇒ unmixing = driving output PDF far from Gaussian

- Minimum Marginal entropy
- Maximum Marginal negentropy
- Maximum absolute/square kurtosis
- ...

Optimal Extraction ?

If one particular source has to be extracted, how can we detect when its extraction is optimized ?

- separation of one specific source \neq global separation
→ example

Experimental context [1/2]

m sources
 n linear mixtures } $m \leq k \leq n$ k mixtures used by the algorithm
PCA from k to m

- Ideal mixtures:

↳ Same extraction for $k=i$ and $k=j$

- 'Real-World' (noisy) mixtures of (in)dependent sources:

↳ Different extraction for $k=i$ or $k=j$

↓
Estimation of extraction quality of each source vs k

Experimental context [2/2]

k mixtures selected among n and PCA from k to m if $k > m$

■ Noiseless mixtures

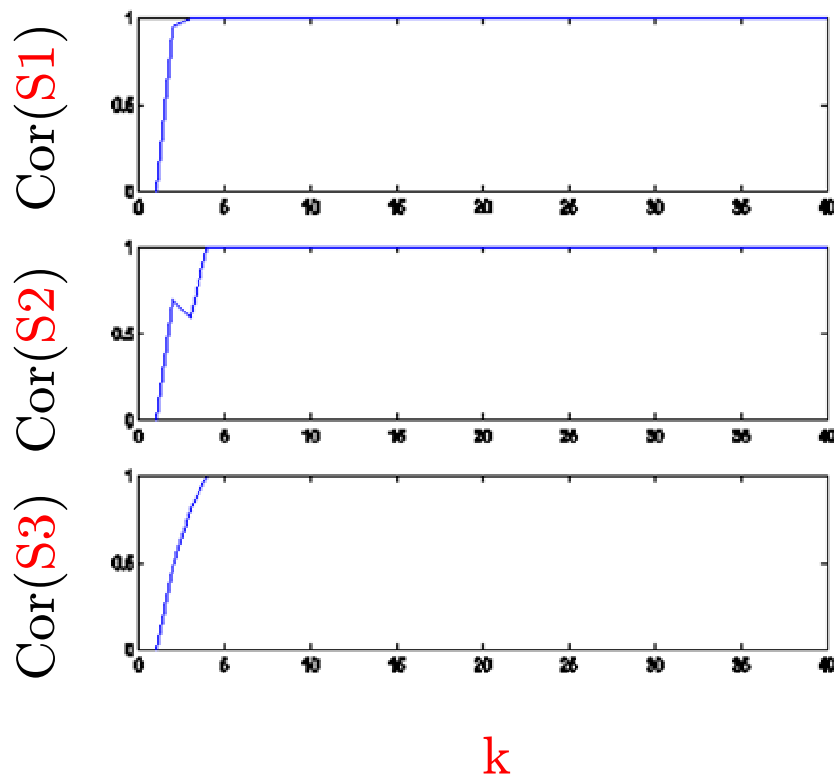

■ Noisy mixtures

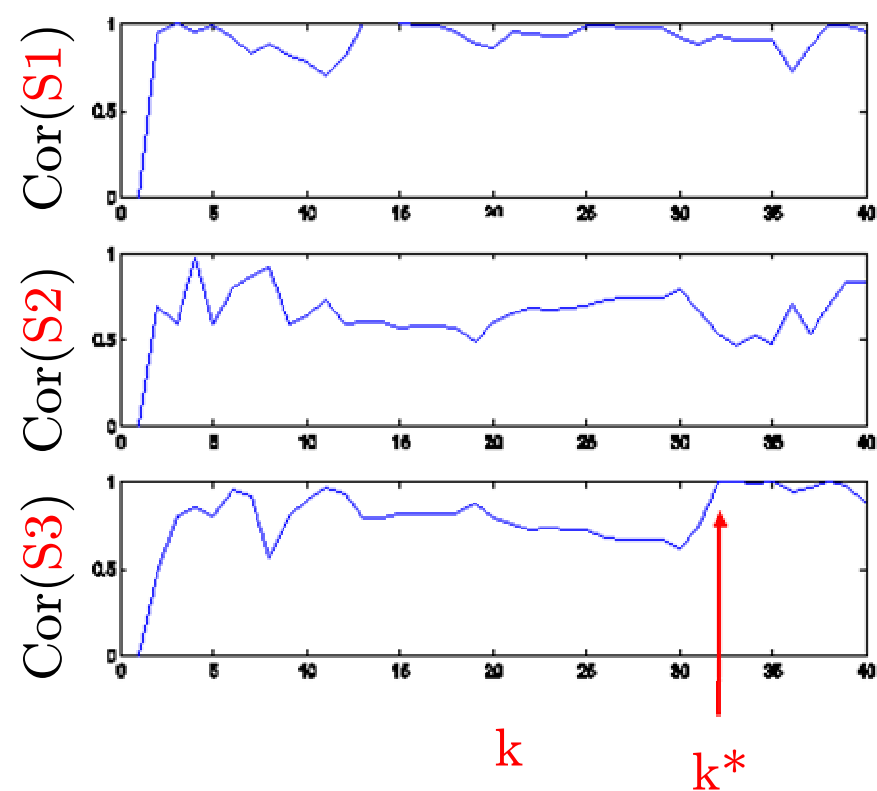

Ex. To extract $S3$ in the best way \rightarrow finding blindly k^* !

Optimal Extraction ?

If one particular source has to be extracted, how can we detect when its extraction is optimized ?

- Such cases exist in real-world context
 - example
- How can we blindly detect k^* ???
 - Blind extraction measures without knowing sources (no correlations) or the mixing system (no SIR) ?



Maybe we can use the Φ 's !

Blind Estimator of Local Performances ?

▪ Independence: Global criterion (on the set of outputs)

▪ Nongaussianity: Local criterion (on one specific output)

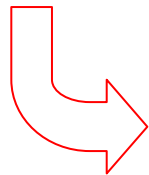

Marginal (neg)entropies and kurtoses !

Test on Real-world mixtures:

- Noisy mixtures
- Dependent sources

High-Noise mixtures of indep. sources

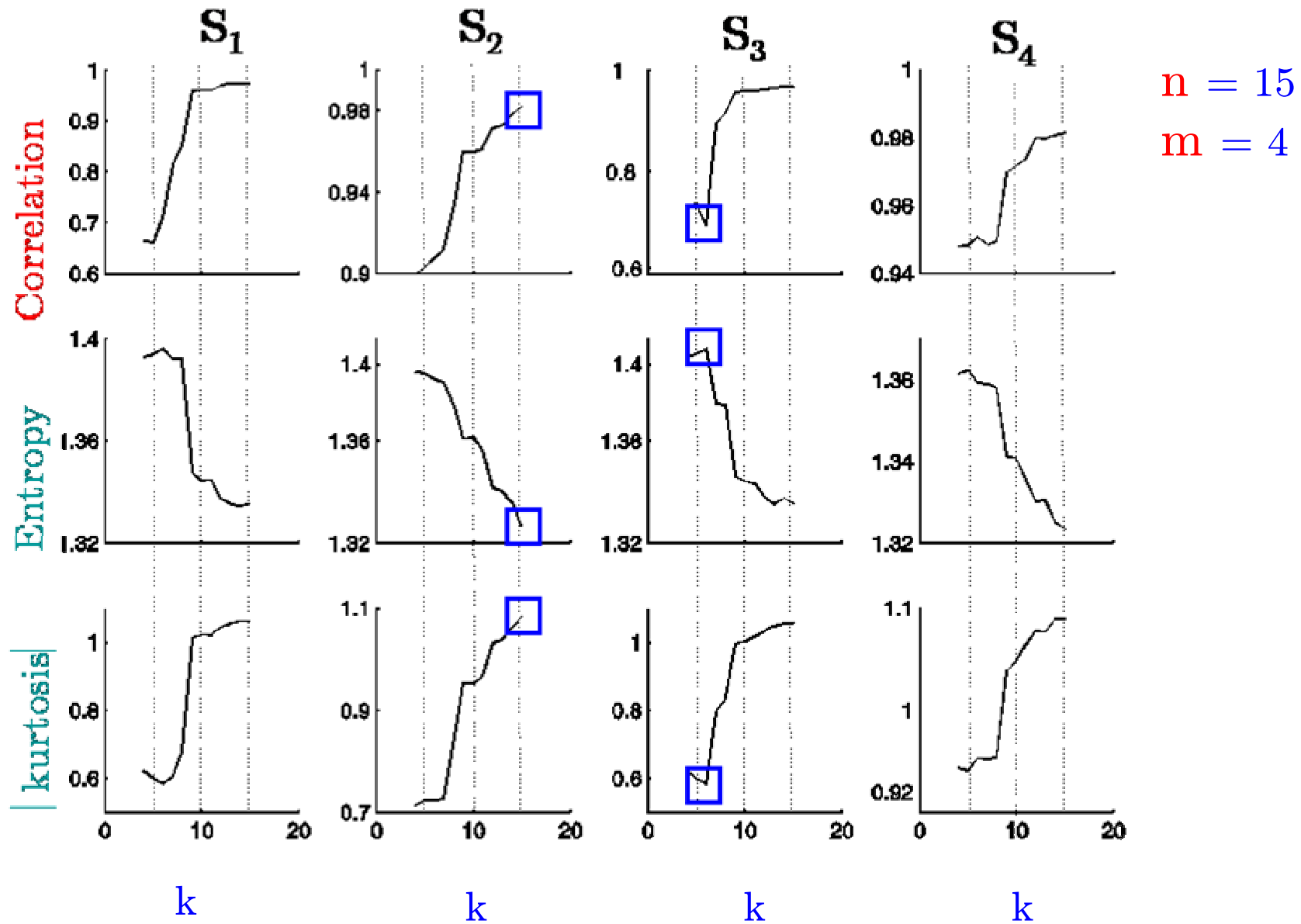

Low-noise mixtures of low-dep. sources

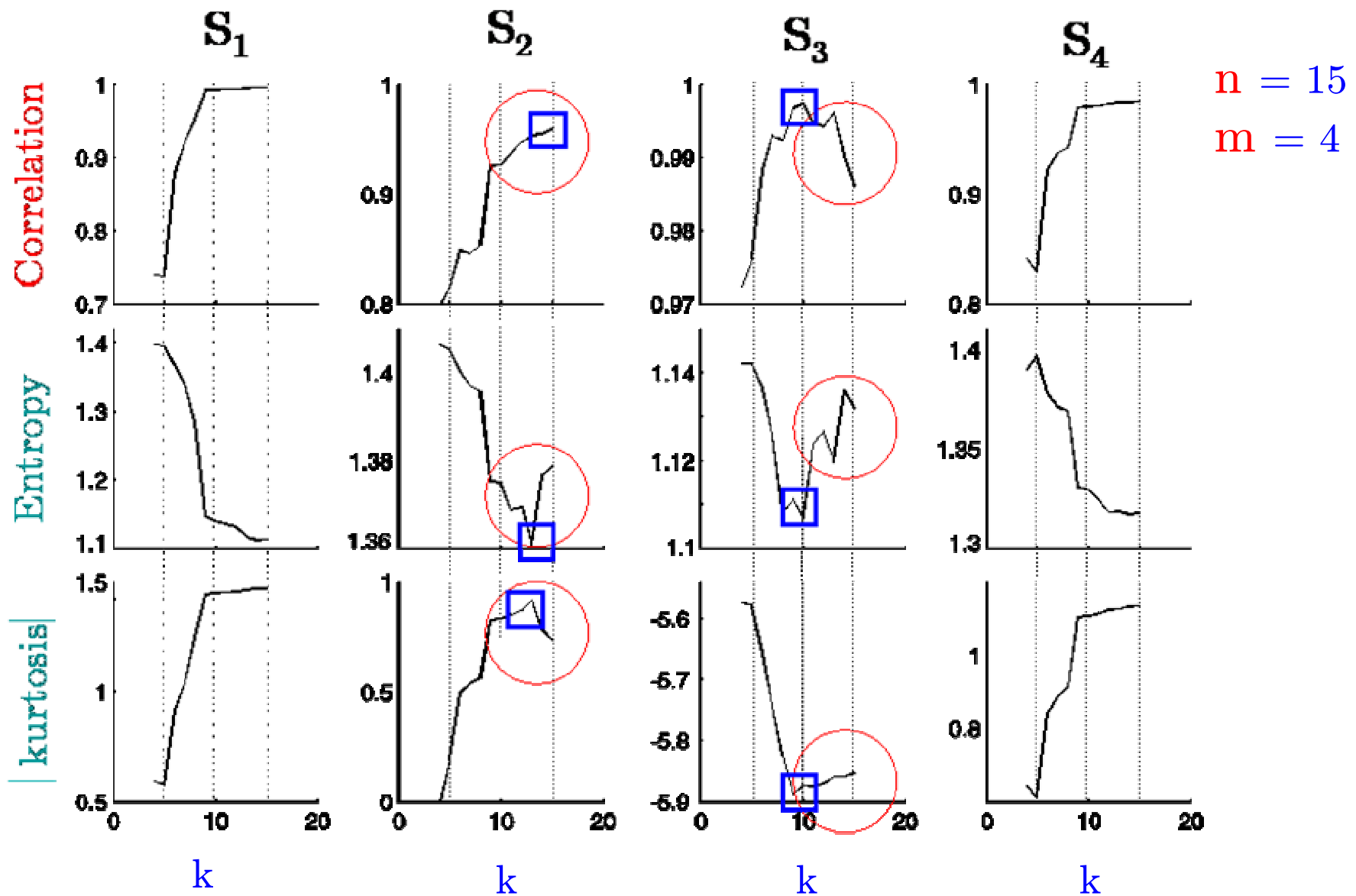

Conclusion

- In **real-world** mixtures, optimizing **global** extraction

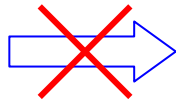

optimizing the **extraction of each source**, one by one

- Often, one specific source **S_k** is needed (FECG extraction, denoising,...)
- How to **identify** when **S_k** is **extracted** in the best way ?
 - No correlations (Blind applications)
 - if sources are **independent** : **NonGaussianity** (=local criteria) **OK**
 - if sources are **dependent** : **ICA** criterion are **NOT** reliable

Note: The **Y** MUST BE ORDERED w.r.t. **S**